

ECOMAX PLUS SERIES

GLASSWASHERS



Undercounter Glasswasher

ECO+G515-10D

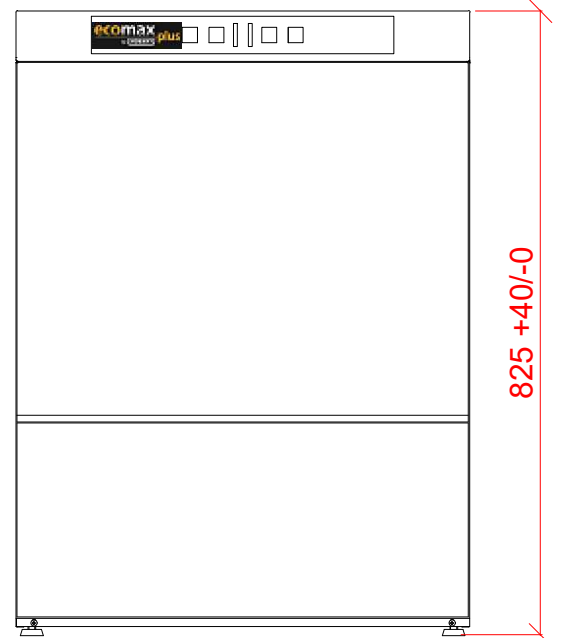
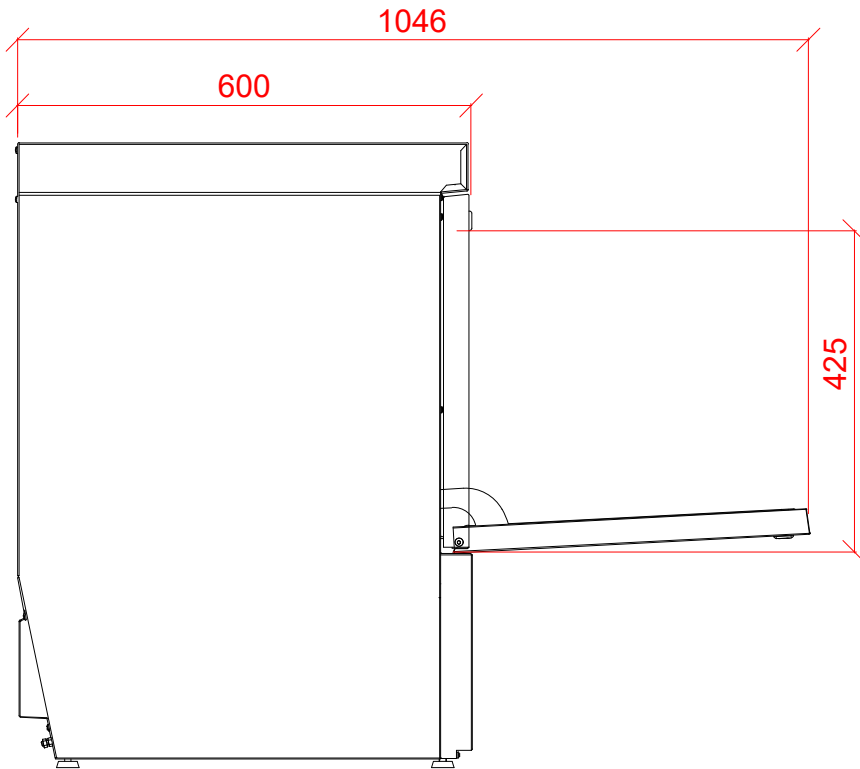
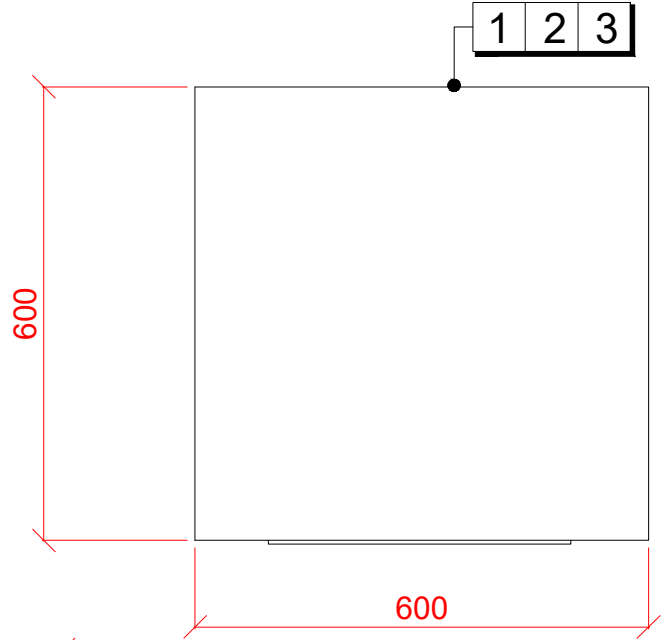

1 Water

22mm CONNECTION VIA 2 METRE FLEXIBLE HOSE, FEMALE TERMINATION.

WATER SUPPLY 10 TO 60°C (2° TO 8° CLARK MAX) @ 0.6 TO 6.0 BAR MAX. INITIAL TANK FILL 10.6 LITRES.

RINSE WATER USAGE 2.0 LITRES PER CYCLE. MAX USAGE 60 CYCLES PER HOUR.

OUR MACHINES ARE SUPPLIED WITH CLASS 'AB' AIR GAP AS STANDARD.

2 Drain

DRAIN - 2 METRE FLEXIBLE HOSE TO A 40 mm TRAPPED STANDPIPE 600mm MAX A.F.F.L.

FLOW RATE 30 LITRES PER MINUTE.

Other Services

RINSE AGENT HOSE - 2.5 METRE FLEXIBLE. DETERGENT HOSE - 2.5 METRE FLEXIBLE.

3 Electric

6.7kW 400/50/3 FUSED AT 13amps/ PHASE.

CONFIGURABLE TO:

5.6kW 230/50/1 + N + E FUSED AT 25amps OR 2.6kW 230/50/1 + N + E FUSED AT 13amps.

MACHINE SUPPLIED WITH 2.5 METRES OF CABLE

Notes

APPROX WEIGHTS:
EMPTY: 65kg's WITH WATER: 87kg's
+40mm FEET HEIGHT ADJUST

PLOT SCALE: 1:10

RIGHT TO MAKE NECESSARY CHANGES IS RESERVED