

Undercounter Dishwasher with in-built Softener

F504S-20C

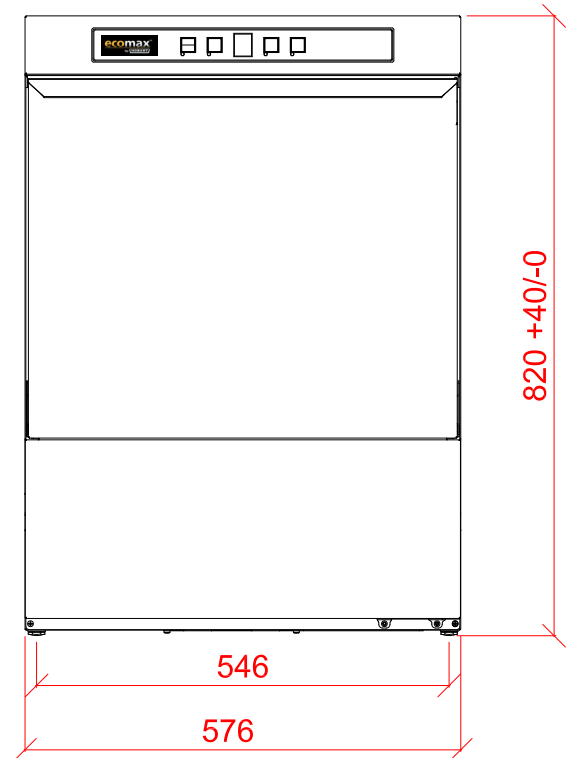
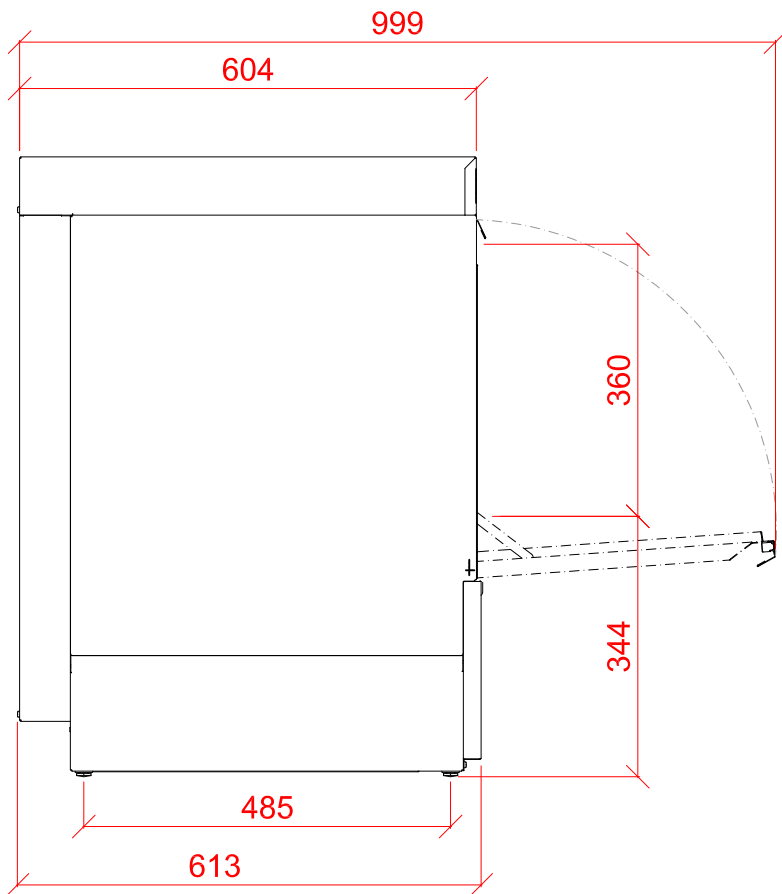
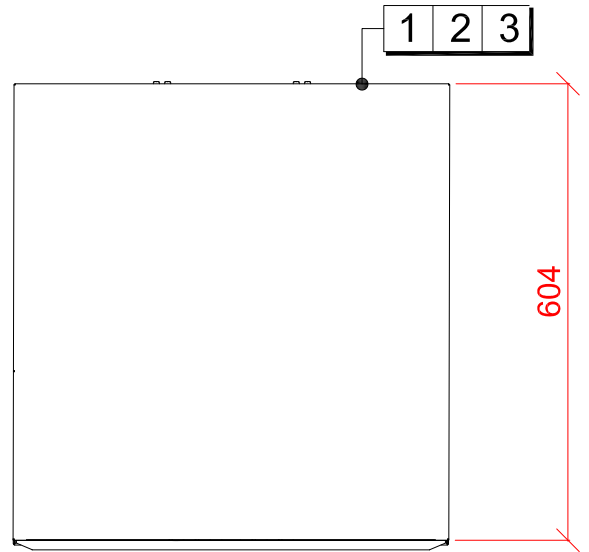

1 Water

22mm CONNECTION VIA 2 METRE FLEXIBLE HOSE FEMALE TERMINATION.

WATER SUPPLY 15°C TO 65°C @ 0.8 TO 6.0 BAR MAX.
INITIAL TANK FILL 25 LITRES.
RINSE WATER USAGE 2.0 LITRES PER CYCLE. MAX USAGE 120 LITRES PER HOUR.
OUR MACHINES ARE SUPPLIED WITH CLASS 'AB' AIR GAP AS STANDARD.

2 Drain

DRAIN: 2.0 METRE FLEXIBLE HOSE TO A 40mm TRAPPED STANDPIPE 650mm MAX A.F.F.L.

FLOW RATE 30 LITRES PER MINUTE.

Other Services

RINSE AGENT HOSE - 2.5 METRE FLEXIBLE.
DETERGENT HOSE - 2.5 METRE FLEXIBLE.

3 Electric

4.1kW 230/50/1 FUSED AT: 1 x 25amps.
CONFIGURABLE TO:
5.9kw 400/50/3 FUSED AT: 3 x 16amps
2.2kW 230/50/1 FUSED AT: 1 x 13 amps
MACHINE SUPPLIED WITH 2.0 METRES OF CABLE

Notes

+40mm ADJUSTMENT FOR FEET
NET WEIGHT 46kg.

PLOT SCALE: 1:10