

Glasswasher with inbuilt Softener

G404S-12C

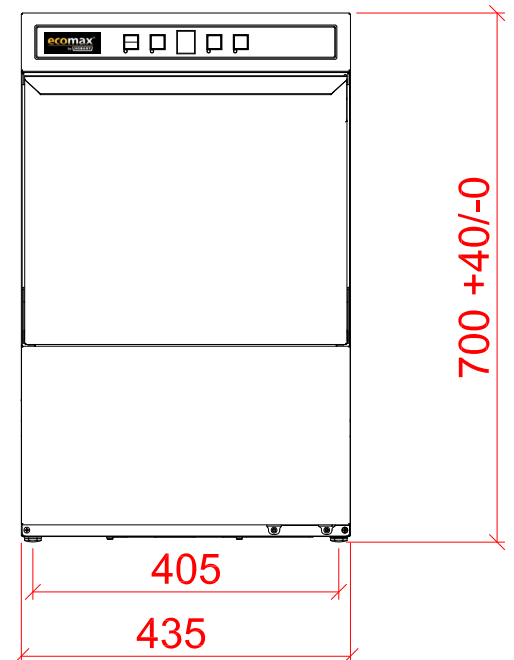
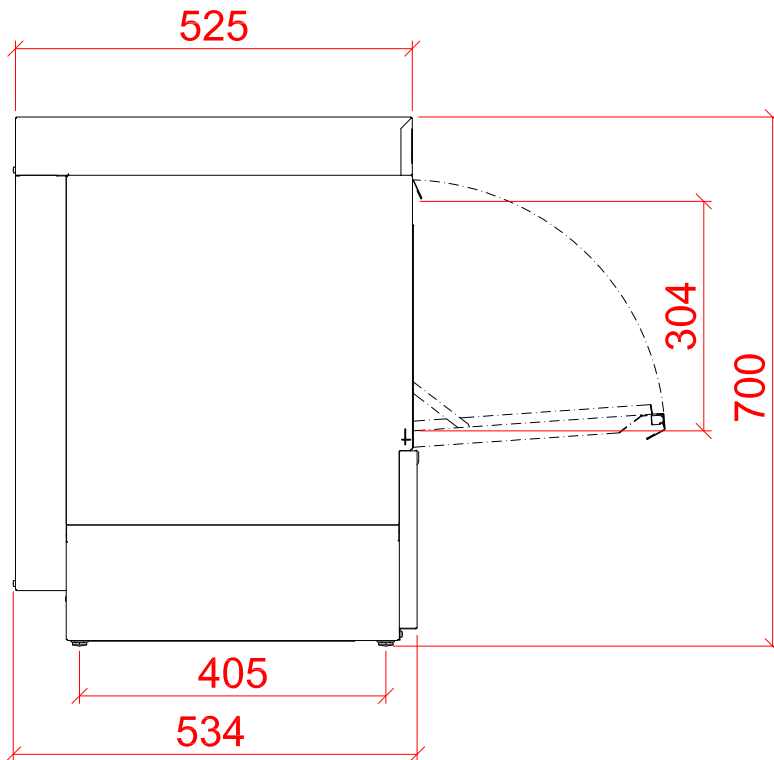
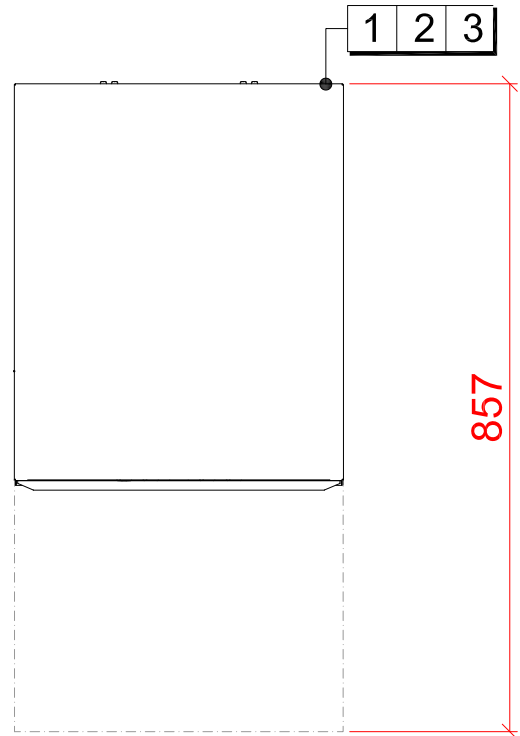

1 Water

22mm CONNECTION VIA 2 METRE FLEXIBLE HOSE, FEMALE TERMINATION.

WATER SUPPLY 15°C TO 60°C (2° TO 8° CLARK MAX)@ 2.0 TO 6.0 BAR MAX. INITIAL TANK FILL 10 LITRES. RINSE WATER USAGE 1.8 LITRES PER CYCLE. MAX USAGE 108 LITRES PER HOUR. OUR MACHINES ARE SUPPLIED WITH CLASS 'AB' AIR GAP AS STANDARD.

2 Drain

DRAIN: 2.0 METRE FLEXIBLE HOSE TO A 40mm TRAPPED STANDPIPE 650mm MAX A.F.F.L.

FLOW RATE 30 LITRES PER MINUTE.

Other Services

RINSE AGENT HOSE - 2.5 METRE FLEXIBLE. DETERGENT HOSE - 2.5 METRE FLEXIBLE.

3 Electric

2.1kW 230/50/1 FUSED AT: 1 x 13amps CONFIGURABLE TO:
5.7kW 400/50/3 FUSED AT: 3 x 16amps
3.9kW 230/50/1 FUSED AT: 1 x 20amps

MACHINE SUPPLIED WITH 2.0 METRES OF CABLE

Notes

+40mm ADJUSTMENT FOR FEET. FOR RACK SIZE: 385mm x 385mm to 396mm x 396mm

PLOT SCALE: 1:10

RIGHT TO MAKE NECESSARY CHANGES IS RESERVED