

Hood Type Dishwasher

H604-12B

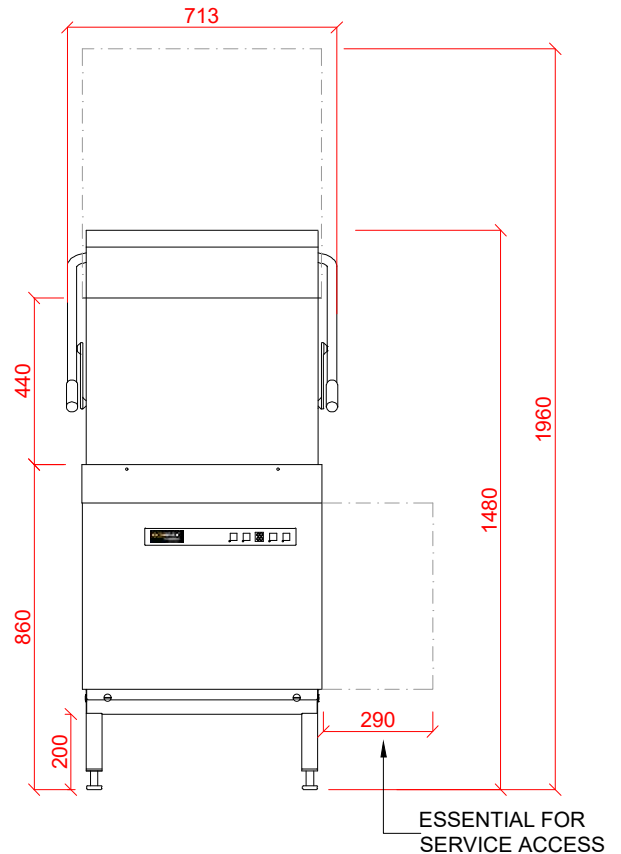
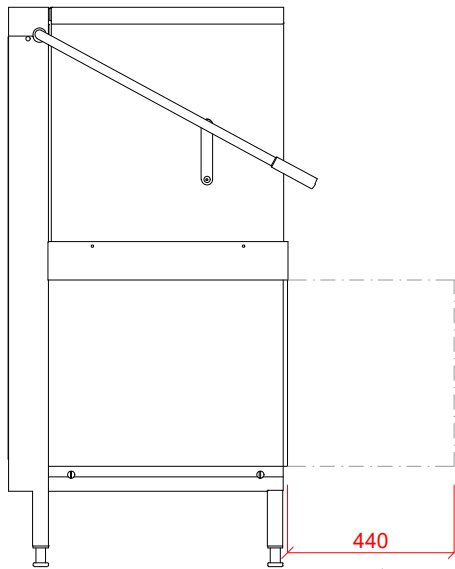
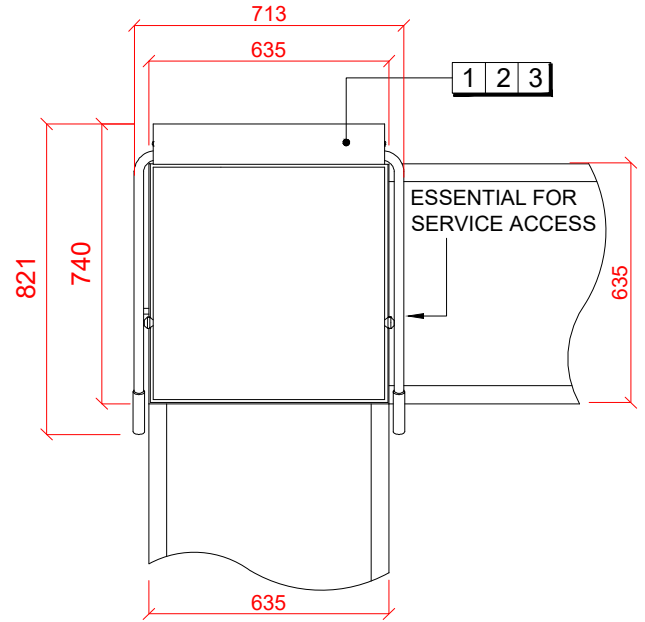

ESSENTIAL FOR SERVICE ACCESS

ESSENTIAL FOR SERVICE ACCESS

1 Water

22mm CONNECTION VIA 2 METRE FLEXIBLE HOSE, FEMALE TERMINATION. WATER SUPPLY 60°C (2° TO 8° CLARK MAX) @ 0.4 TO 10 BAR MAX. INITIAL TANK FILL 21 LITRES. RINSE WATER USAGE 2.3 LITRES PER CYCLE. OUR MACHINES ARE SUPPLIED WITH CLASS 'AB' AIR GAP AS STANDARD.

2 Drain

DRAIN - 2 METRE FLEXIBLE HOSE TO A 40 mm TRAPPED STANDPIPE 500mm A.F.F.L.

FLOW RATE 30 LITRES PER MINUTE.

Other Services

RINSE AGENT HOSE - 2.0 METRE FLEXIBLE. DETERGENT HOSE - 2.0 METRE FLEXIBLE.

3 Electric

6.6kW 400/50/3N FUSED AT: 3 x 16amps Configurable to Single Phase 4.5kW 230/50/1 FUSED AT: 25amps

MACHINE SUPPLIED WITH 2.5 METRES OF CABLE.

Notes