

# Two-Level Washers

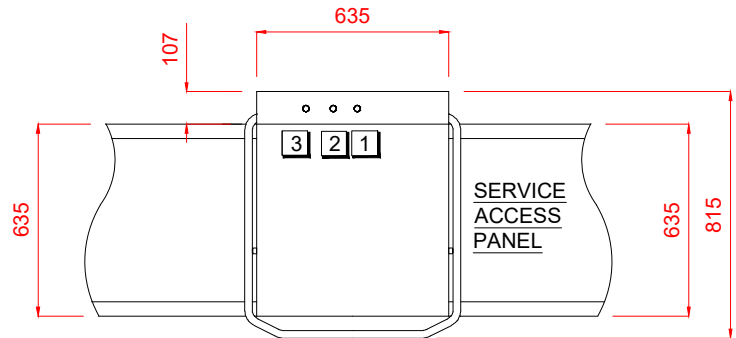

## Dual Hood Type Pass Through Dishwasher & Glasswasher with Inbuilt Softener

TLWS-10A

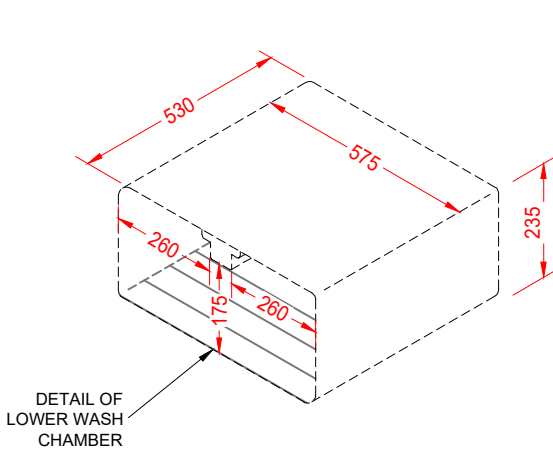
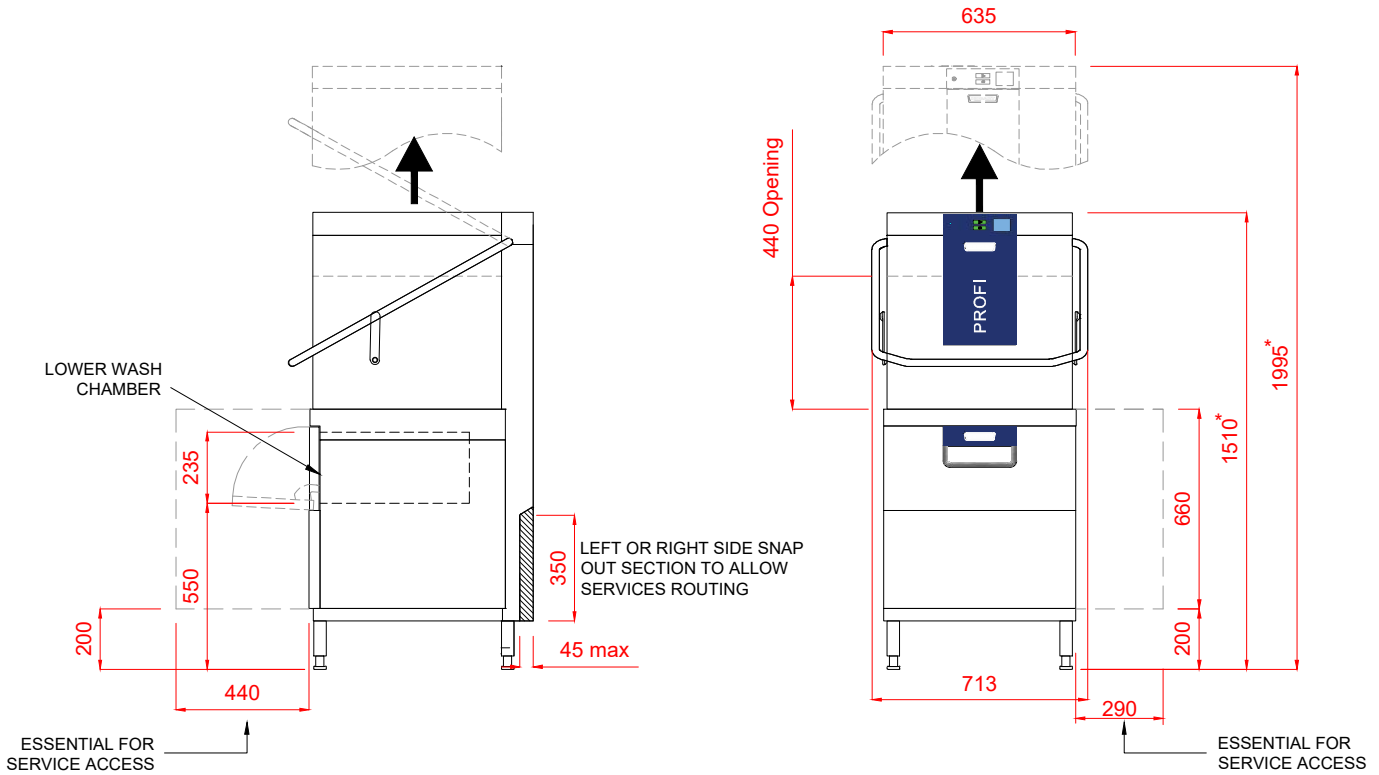

### 1 Water

22mm CONNECTION VIA 2.0 METRE FLEXIBLE HOSE, FEMALE TERMINATION.

WATER SUPPLY 10°C TO 60°C (2° TO 8° CLARK MAX) @ 0.5 TO 10.0 BAR MAX. INITIAL TANK FILL 30 LITRES. USAGE MIN 5 LITRES PER WASH CYCLE. MAX CYCLES PER HOUR - 120

OUR MACHINES ARE SUPPLIED WITH CLASS 'AB' AIR GAP AS STANDARD.

### 2 Drain

DRAIN - 2.0 METRE FLEXIBLE HOSE (50mm diam) TO A TRAPPED STANDPIPE 750mm MAX AFFL

FLOW RATE 30 LITRES PER MINUTE. DRAIN RATE TYPICALLY 3 MINUTES.

### Other Services

RINSE AGENT HOSE - 2.0 METRE FLEXIBLE. DETERGENT HOSE - 2.0 METRE FLEXIBLE.

### 3 Electric

13.6kW 400/50/3 + N + PE FUSED AT 25amps / PHASE.

#### CONFIGURABLE TO:

10.4kW 400/50/3 + N + PE FUSED AT 16amps / PHASE. MACHINE SUPPLIED WITH 2.5 METRES OF CABLE (3 PHASE).

### Notes

\* = ±25mm

PLOT SCALE: 1:25

RIGHT TO MAKE NECESSARY CHANGES IS RESERVED